

PTS plus

Software rev: V 1.00 & above

Easy Reference:

Model name of the scale:	
Serial number of the unit:	
Software revision number (Displayed when power is first turned on):	
Date of Purchase:	
Name of the supplier and place:	

CONTENTS

P.N. 3.10.6.6.15393, Rev A, November 2019

1.0	PTS PLUS SPECIFICATION.....	1
2.0	SAFETY.....	1
3.0	INSTALLATION.....	5
4.0	AE403 ASSEMBLY.....	6
5.0	CALIBRATION.....	9
6.0	TROUBLE SHOOTING.....	10
7.0	MAINTENANCE.....	11
8.0	SERVICE INFORMATION.....	12
	WARRANTY STATEMENT.....	13

1.0 PTS PLUS SPECIFICATION

Model	PTSplus 2000	PTSplus 5000a
Load cell Capacity	2000 kg	5000 Lb
Resolution	0.5 kg	1Lb
Readability	0.5kg	1lb /0.5kg
Repeatability (sd)	1kg	2lb / 1kg
Linearity	1kg	2lb / 1kg
Fork length	1150mm (45.25")	48" (1220mm)
Fork Width (each)	160mm (6.3")	6.3" (160mm)
Fork Width (total)	540mm (21.25")	26.77" (680mm)
Fork Height	77mm increasing to 192mm (3" – 7.5")	3" – 7.5" (77mm increasing to 192mm)
Net Weight	125 kg (275 Lb)	297 Lb (135 kg)

2.0 SAFETY

- To prevent damage to the scale, please read these operating instructions thoroughly.
- When using the pallet truck, please keep the handle in the DRIVE position.
- This pallet truck must be operated by trained personnel only.

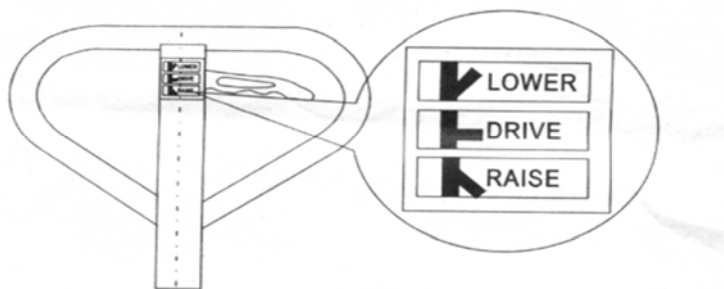

- Check the pallet truck first before using it making sure that the wheels, handles and forks are fitted correctly and secure
- Avoid unsuitable and uneven floor surfaces
- Please wear protective clothing where necessary
- Allow 60cm clearance from the pallet truck when operating.
- Pay attention and focus on the object you are lifting
- Do not overload.

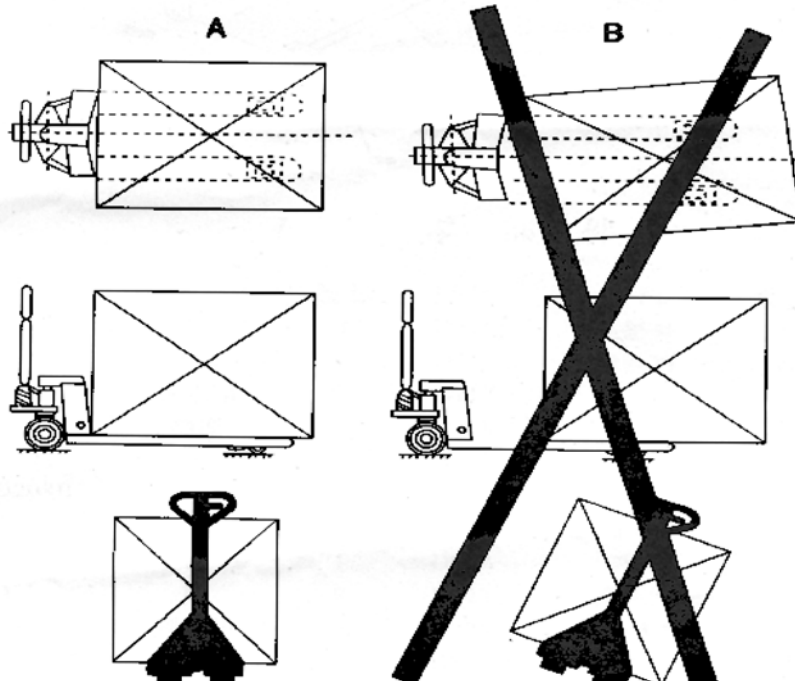

PTS plus 2000

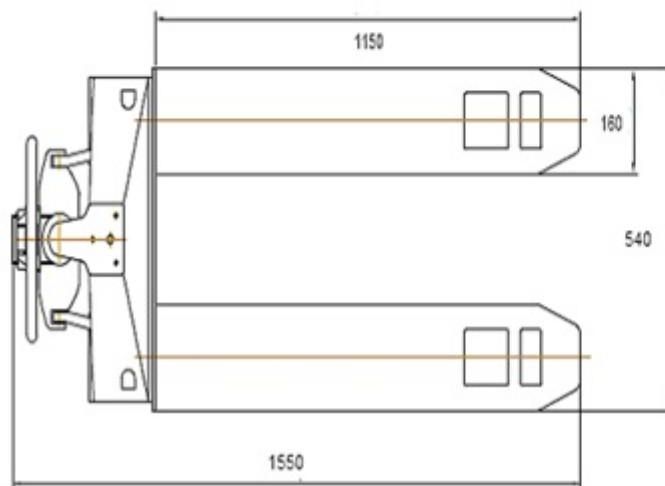
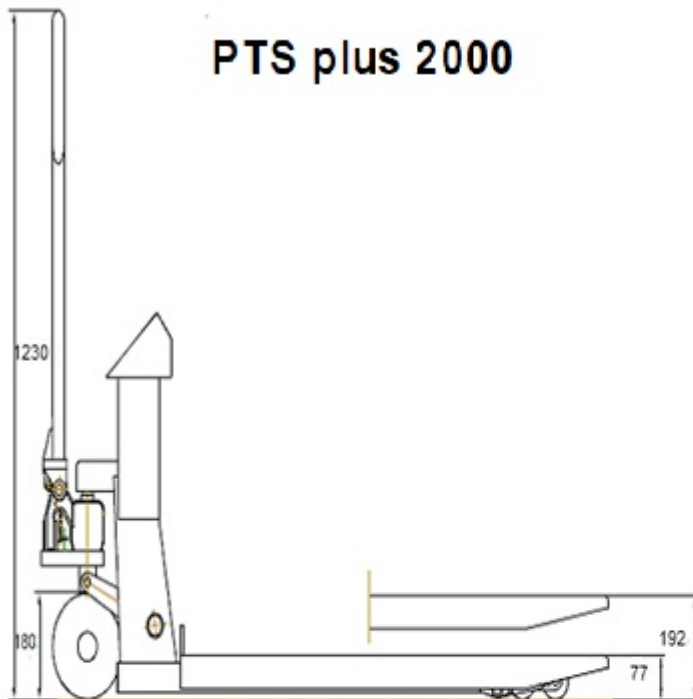

PTS plus 5000

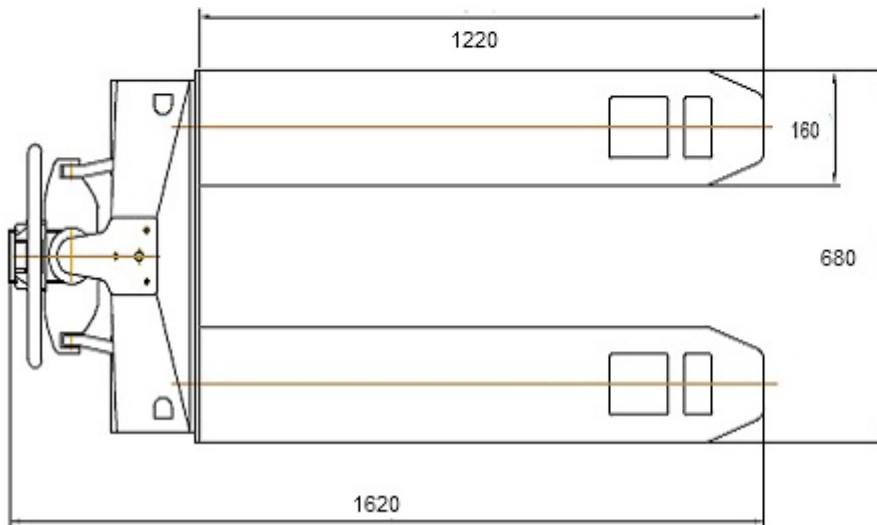
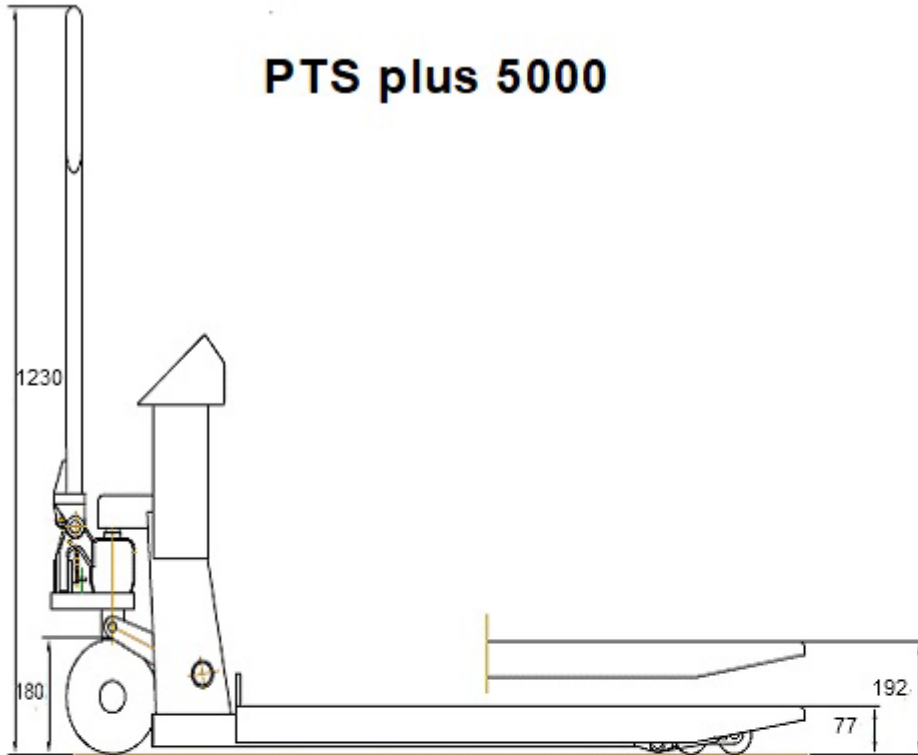

3.0 INSTALLATION

Please follow the installation instructions to ensure correct operation of your PTS plus. In transportation the handle is removed from the truck, this needs to be installed following the instructions below:

NOTE: Do not lower the handle down fully until completing the instructions below.

- 1) Insert the roller pin into the hole of roller rack, securing the handle to the frame
- 2) Fit the split pin through the holes provided.
- 3) Pass the chain through the center hole of the roller pin. Secure the end of the chain to the slot on the end of the unloading plate.
- 4) Remove the transit rod before use. Press the handle down only far enough to release any pressure on the transit rod, then pull the transit rod free.

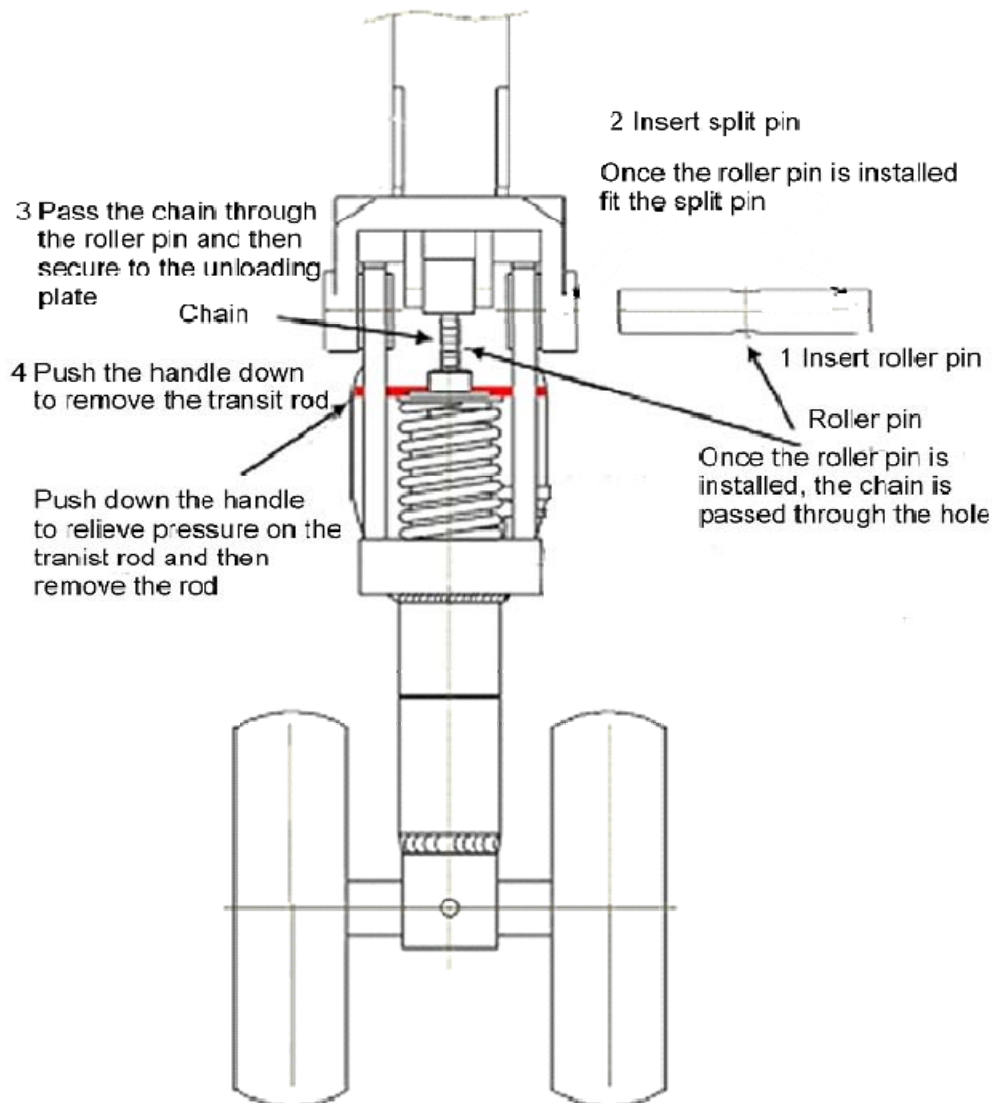

4.0 AE403 ASSEMBLY

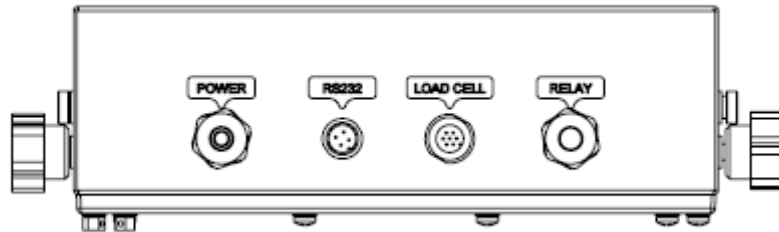

Rear view of AE 403 Indicator

Fit AE403 load cell connecting cable according to the picture below:

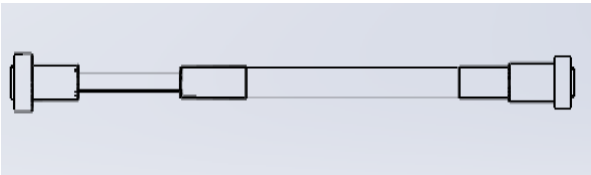

AE 403 indicator connecting

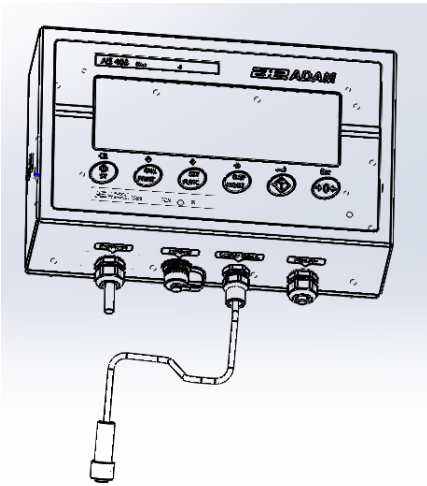

Fit 7pin connector here; plug must tight to seal it up and also prevent from getting loose, otherwise, it will affect weighing.

Fit the connecting cable to the indicator box and fix it with the 4pcs of drive pipes and 4pcs of M6X40 socket head cap screws, tight it with the 5# Allen key provided.

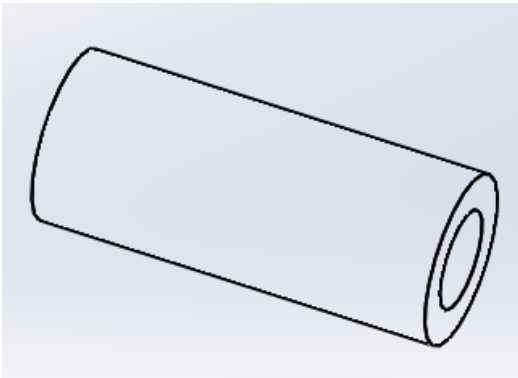

AE403 drive pipe

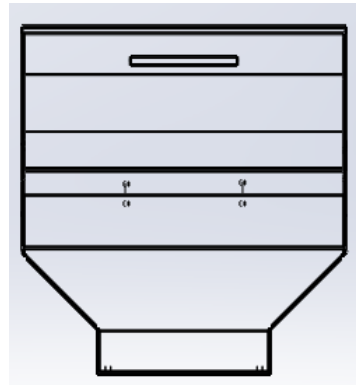

Indicator box

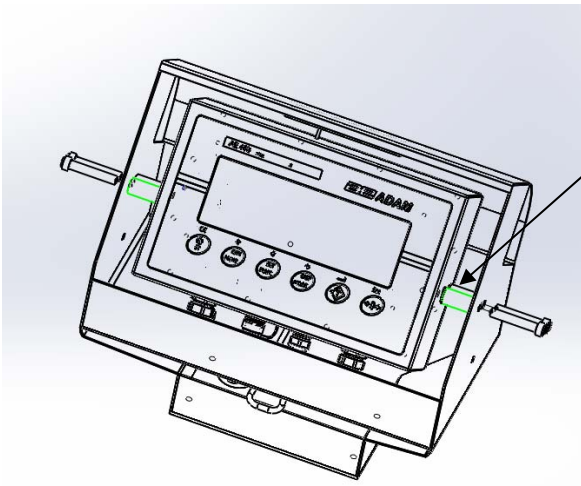

4pcs of M6X40 socket head cap screws

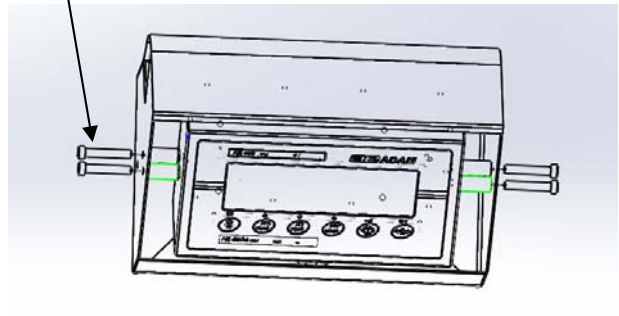

Fit the indicator box with 4pcs of M5 socket head cap screws, 4pcs of M5 spacers, 4pcs of M5 flat gaskets and fix it tight with 4# Allen key.

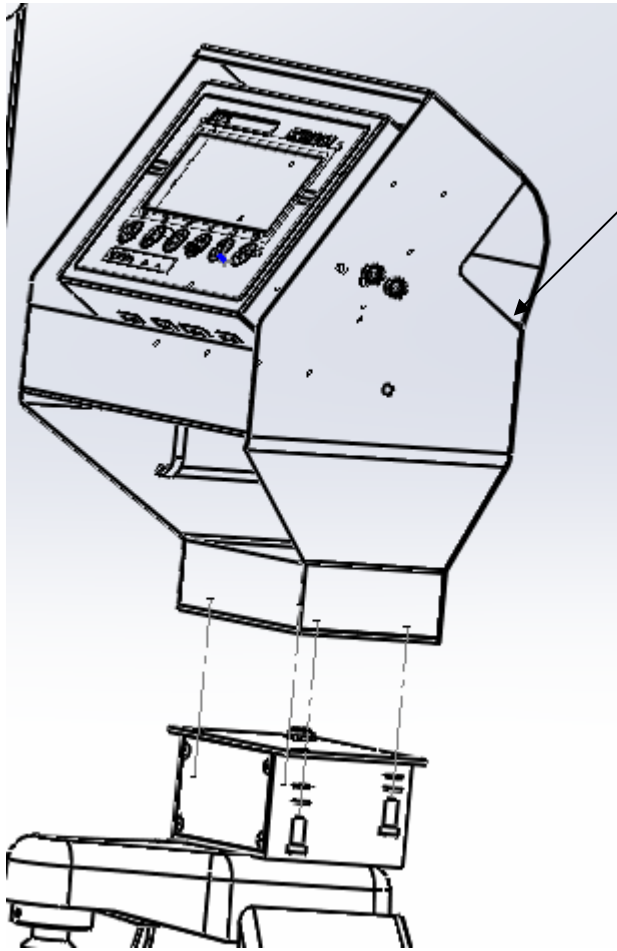

M5 spacer
M5 flat gasket
M5X18 socket head cap screw

Fit AE403 load cell cable 5pin connector to the scale according to the picture below.

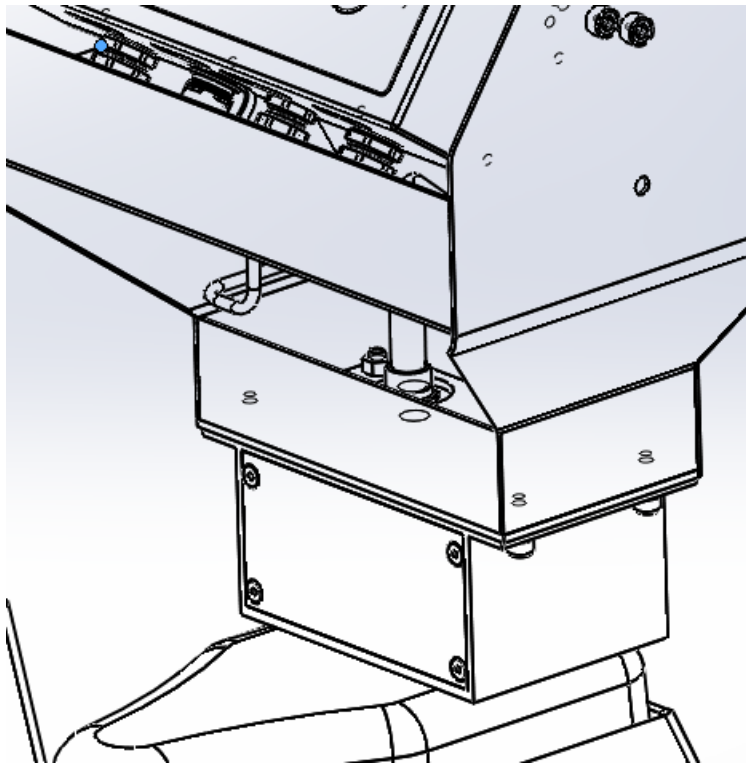

Fit AE403 load cell cable 5pin connector to the scale

Load cell connecting definition (5pin aviation waterproof connector), see the area in the circle:

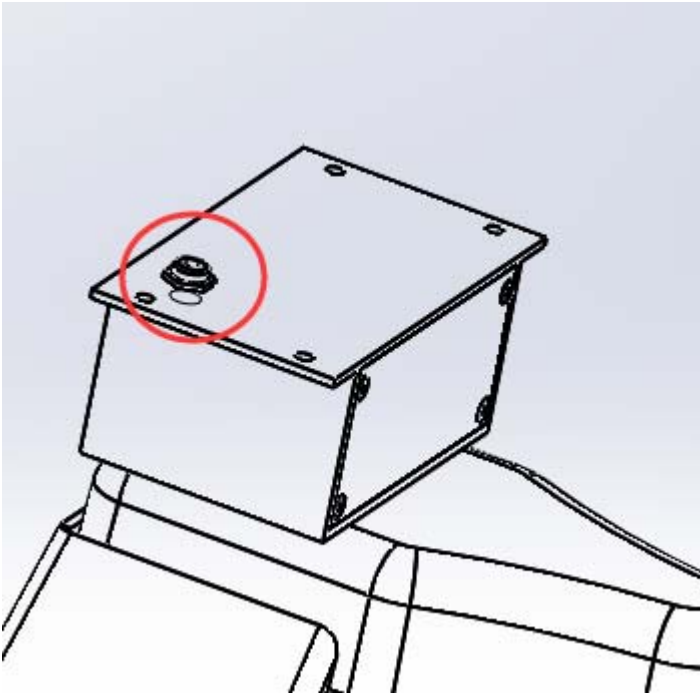

- 1pin: (E+) red cable
- 2pin: (E-) black cable
- 3pin: (SH) shield cable
- 4pin: (S+) green cable
- 5pin: (S-) white cable

5.0 CALIBRATION

The PTS plus is factory calibrated, if further information is required for re-calibrating the scale the procedure is as follows:

- Turn on the power and wait for the scale to configure.
- Before configuration is completed, hold down the **[Tare]** ↵ key to bring up the user password information screen.
- To enter the password, use the directional buttons ↑ or ↓ to scroll through numbers 1-9. Use the → directional key to move to the next digit.
- Entering the correct password **[1000]** and pressing **[Tare]** for confirmation will bring you to the user setup menu;
- Within the menu, use the directional buttons ↑ or ↓ to scroll through the settings until 'U-cal' appears on the display. Press the **[Tare]** ↵ key to select.

- After pressing **[Tare]** ↵, 'noload' should appear on the display. Use the directional button ↑ to switch to 'load1' and set the desired weight limit of the test object to be placed on the scale using the ↑ or ↓ directional buttons and the → directional key to move to the next digit. Press the **[Tare]** ↵ key to confirm.
- After pressing **[Tare]** ↵, 'Load' will appear on the display. Place the calibration test weight that matches the weight previously entered onto the scale weighing pan and press the **[Tare]** ↵ key to confirm.
- Pressing Tare should bring up the 'Load 2' option on the display. Follow the same procedure as before by setting a new weight and adding the appropriate calibration weight and press the **[Tare]** ↵ key to confirm.
- Pressing **[Tare]** ↵ will reconfigure the scale and bring the user back to the regular weighing mode.

6.0 TROUBLE SHOOTING

No	Problem	Cause	Solution
1	Forks cannot ascend to the maximum height	Inadequate hydraulic oil in the chamber.	Refill oil chamber. See Figure 1.
2	Forks can not be raised	No hydraulic oil. Oil is not clean.	Refill oil chamber. See Figure 1. Change oil
3	Forks can not descend	Position of the goods are to one side of the truck	Relocate load.
4	Oil spillage	Aging or damaged seals.	Call for Service.
5	Forks descend when the trigger is not in descend position	The oil could be unclean Some parts of the hydraulic system are damaged.	Change the oil. Vent the air. Call for Service.

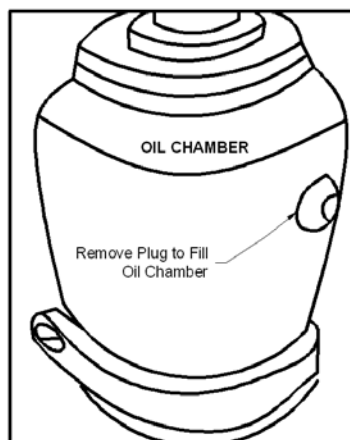

7.0 MAINTENANCE

- Please check the oil every six months , we suggest you use hydraulic oil: ISO VG32
- Whilst in transit air may enter into the hydraulic pump, this may result in the forks not raising when first used. Please move the handle up and down several times to allow air to escape.
- Routine maintenance is necessary. You should focus on the wheels and handle assemblies. When the truck is not in use, remove the items on the forks, and reset the forks to their lowest position.
- All the bearings and axles have been lubricated, please check at regular intervals

8.0 SERVICE INFORMATION

This manual covers the details of operation. If you have a problem with the scale that is not directly addressed by this manual then contact your supplier for assistance. In order to provide further assistance, the supplier will need the following information which should be kept ready:

A. Details of your company

Name of your company:

Contact person's name:

Contact telephone, e-mail, fax or any other methods:

B. Details of the unit purchased

(This part of information should always be available for any future correspondence. We suggest you to fill in this form as soon as the unit is received and keep a print-out in your record for ready reference.)

Model name of the scale:	
Serial number of the unit:	
Software revision number (Displayed when power is first turned on):	
Date of Purchase:	
Name of the supplier and place:	

C. Brief description of the problem

Include any recent history of the unit. For example:

- Has it been working since it's delivered
- Has it been in contact with water
- Damaged from a fire
- Electrical Storms in the area
- Dropped on the floor, etc.

WARRANTY STATEMENT

Adam Equipment offers Limited Warranty (Parts and Labour) for any components that fail due to defects in materials or workmanship. Warranty starts from the date of delivery.

During the warranty period, should any repairs be necessary, the purchaser must inform its supplier or Adam Equipment Company. The company or its authorised Technician reserves the right to repair or replace the components at any of its workshops at no additional cost, depending on the severity of the problems. However, any freight involved in sending the faulty units or parts to the Service Centre should be borne by the purchaser.

The warranty will cease to operate if the equipment is not returned in the original packaging and with correct documentation for a claim to be processed. All claims are at the sole discretion of Adam Equipment.

This warranty does not cover equipment where defects or poor performance is due to misuse, accidental damage, exposure to radioactive or corrosive materials, negligence, faulty installation, unauthorised modifications or attempted repair, or failure to observe the requirements and recommendations as given in this User Manual.

This product may include a rechargeable battery that is designed to be removed and replaced by the user. Adam Equipment warrants that it will provide a replacement battery if the battery manifests a defect in materials or workmanship during the initial period of use of the product in which the battery is installed.

As with all batteries, the maximum capacity of any battery included in the product will decrease with time or use, and battery cycle life will vary depending on product model, configuration, features, use, and power management settings. A decrease in maximum battery capacity or battery cycle life is not a defect in materials or workmanship, and is not covered by this Limited Warranty.

Repairs carried out under the warranty do not extend the warranty period. Components removed during warranty repairs become company property.

The statutory rights of the purchaser are not affected by this warranty. The terms of this warranty is governed by the UK law. For complete details on Warranty Information, see the terms and conditions of sale available on our web-site.

WEEE 2012/19/EU

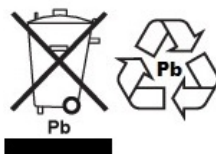

This device may not be disposed of in domestic waste. This also applies to countries outside the EU, per their specific requirements. Disposal of batteries (if fitted) must conform to local laws and restrictions.

Cet appareil ne peut être éliminé avec les déchets ménagers. L'élimination de la batterie doit être effectuée conformément aux lois et restrictions locales.

Dieses Gerät nicht mit dem Hausmüll entsorgt.

Dispositivo no puede ser desechado junto con los residuos domésticos

Dispositivo non può essere smaltito nei rifiuti domestici.

FCC / IC CLASS A DIGITAL DEVICE EMC VERIFICATION STATEMENT

NOTE: This equipment has been tested and found to comply with the limits for a Class A digital device, pursuant to Part 15 of the FCC rules and Canadian ICES-003/NMB-003 regulation. These limits are designed to provide reasonable protection against harmful interference when the equipment is operated in a commercial environment. This equipment generates, uses and can radiate radio frequency energy and, if not installed and used in accordance with the instruction manual, may cause harmful interference to radio communications. Operation of this equipment in a residential area is likely to cause harmful interference in which case the user will be required to correct the interference at his own expense.

CALIFORNIA PROPOSITION 65 - MANDATORY STATEMENT

WARNING: This product includes a sealed lead-acid battery which contains chemicals known to the State of California to cause cancer and birth defects or other reproductive harm.



Adam Equipment products have been tested with, and are always supplied with mains power adaptors which meet all legal requirements for the intended country or region of operation, including electrical safety, interference and energy efficiency. As we often update adaptor products to meet changing legislation it is not possible to refer to the exact model in this manual. Please contact us if you need specifications or safety information for your particular item. Do not attempt to connect or use an adaptor not supplied by us.

ADAM EQUIPMENT is an ISO 9001:2015 certified global company with more than 40 years' experience in the production and sale of electronic weighing equipment.

Adam products are predominantly designed for the Laboratory, Educational, Health and Fitness, Retail and Industrial Segments. The product range can be described as follows:

- Analytical and Precision Laboratory Balances
- Compact and Portable Balances
- High Capacity Balances
- Moisture analysers / balances
- Mechanical Scales
- Counting Scales
- Digital Weighing/Check-weighing Scales
- High performance Platform Scales
- Crane scales
- Mechanical and Digital Electronic Health and Fitness Scales
- Retail Scales for Price computing

For a complete listing of all Adam products visit our website at

www.adamequipment.com

<p>Adam Equipment Co. Ltd. Maidstone Road, Kingston Milton Keynes MK10 0BD UK Phone:+44 (0)1908 274545 Fax: +44 (0)1908 641339 e-mail: sales@adamequipment.co.uk</p>	<p>Adam Equipment Inc. 1, Fox Hollow Rd. Oxford, CT 06478 USA Phone: +1 203 790 4774 Fax: +1 203 792 3406 e-mail: sales@adamequipment.com</p>	<p>AE Adam GmbH. Instenkamp 4 D-24242 Felde Germany Phone +49 (0)4340 40300 0 Fax: +49 (0)4340 40300 20 e-mail: vertrieb@aeadam.de</p>
<p>Adam Equipment S.A. (Pty) Ltd. 7 Megawatt Road, Spartan EXT 22 Kempton Park, Johannesburg, Republic of South Africa Phone +27 (0)11 974 9745 Fax: +27 (0)11 392 2587 e-mail: sales@adamequipment.co.za</p>	<p>Adam Equipment (S.E. ASIA) PTY Ltd 70 Miguel Road Bibra Lake Perth WA 6163 Australia Phone: +61 (0) 8 6461 6236 Fax +61 (0) 8 9456 4462 e-mail: sales@adamequipment.com.au</p>	<p>Adam Equipment (Wuhan) Co. Ltd. A Building East Jianhua Private Industrial Park Zhuanyang Avenue Wuhan Economic & Technological Development Zone 430056 Wuhan P.R.China Phone: + 86 (27) 59420391 Fax + 86 (27) 59420388 e-mail: info@adamequipment.com.cn</p>

© Copyright by Adam Equipment Co. All rights reserved. No part of this publication may be reprinted or translated in any form or by any means without the prior permission of Adam Equipment.

Adam Equipment reserves the right to make changes to the technology, features, specifications and design of the equipment without notice.

All information contained within this publication is to the best of our knowledge timely, complete and accurate when issued. However, we are not responsible for misinterpretations which may result from the reading of this material.

The latest version of this publication can be found on our Website.

www.adamequipment.com