



CBC-M SERIES
with EC type Approval
(P.N. 8226, Revision C6, February 2008)

Software rev.: 3.06A & above

CONTENTS

1.0	INTRODUCTION	2
2.0	SPECIFICATIONS	3
3.0	INSTALLATION	4
3.1	LOCATING THE SCALE	4
3.2	INSTALLATION OF CBC-M SERIES	5
4.0	KEY DESCRIPTIONS	5
5.0	DISPLAYS	6
5.1	WEIGHT DISPLAY	6
5.2	UNIT WEIGHT DISPLAY	7
5.3	COUNT DISPLAY	7
6.0	OPERATION	7
6.1	ZEROING THE DISPLAY	7
6.2	TARING	8
6.3	PARTS COUNTING	8
6.3.1	Setting Unit Weight	8
6.3.2	Counting more parts	9
6.3.3	Automatic part weight updates	10
6.3.4	Check-counting	10
6.3.5	Manually Accumulated Totals	10
6.3.6	Automatic Accumulated Totals	11
7.0	PARAMETERS	11
8.0	RS-232 INTERFACE	11
8.1	INPUT COMMANDS FORMAT	13
8.2	RS-232 SETUP	14
8.3	REAL TIME CLOCK SETUP	15
8.4	AUTO SLEEP FUNCTION	15
9.0	BATTERY AND BACKLIGHT OPERATION	16
9.1	BATTERY	16
9.2	BACKLIGHT FOR LCD	17
10.0	ERROR CODES	17
11.0	CALIBRATION	18
11.1	CALIBRATION PROCEDURE	18
11.2	SECURITY SEALS	18
12.0	REPLACEMENT PARTS AND ACCESSORIES	19
13.0	SERVICE INFORMATION	19

1.0 INTRODUCTION

- The **CBC-M** series provide accurate, fast and versatile counting and check-weighing scales.
- **CBC-M** scales are kilogram only scales.
- There are 4 models of approved scales with capacities up to 30 kg.
- They all have stainless steel weighing platforms on an ABS base assembly.
- All scales are supplied with a RS-232 bi-directional interface and real time clock (RTC).
- All scales have sealed keypad with colour coded membrane switches and there are three large, easy to read liquid crystal type displays (LCD). The LCD's are supplied with a backlight.
- The scales include automatic zero tracking, audible alarm for pre-set weights, automatic tare, accumulation facility that allows the count to be stored and recalled as an accumulated total.

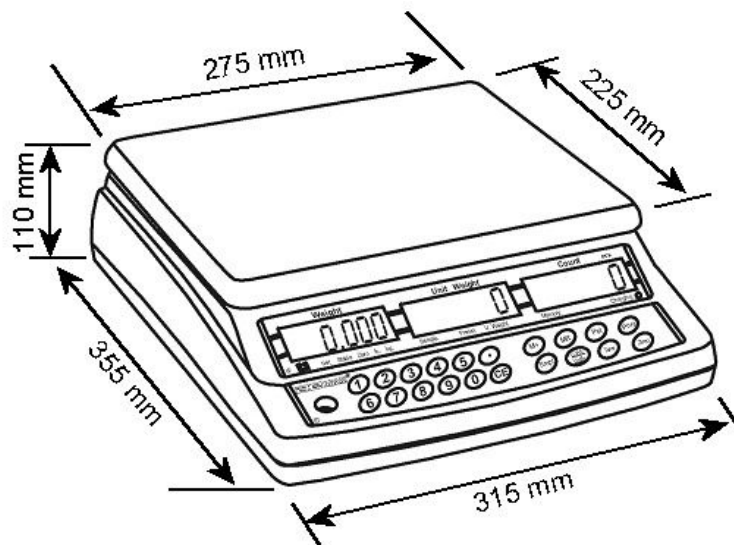

2.0 SPECIFICATIONS



Approved Series

CBC-M SERIES				
Model	CBC 3M	CBC 6M	CBC 15M	CBC 30M
Maximum Capacity	3 kg	6 kg	15 kg	30 kg
d = e =	0.001 kg	0.002 kg	0.005 kg	0.01 kg
Tare Range	-3 kg	-6 kg	-10 kg	-30 kg
Class	III			

Common Specifications	
Stabilisation Time	2 Seconds typical
Operating Temperature	-10°C - 40°C 14°F - 104°F
Power supply	230 VAC 50/60 Hz. 120 VAC available.
Battery	Internal rechargeable battery (~90 hours operation)
Calibration	Only allowed if the seals are broken
Display	3 x 6 digits LCD digital displays
Balance Housing	ABS Plastic, Stainless Steel platform
Pan Size	225 x 275mm 8.9" x 10.8"
Overall Dimensions (wxdxh)	315 x 355 x 110mm 12.4" x 14" x 4.3"
Net Weight	4.1 kg / 9 lb
Applications	Counting Scales
Functions	Parts counting, weighing, accumulating memory, Check-count with alarm
Interface	RS-232 bi-directional interface English, German, French, Spanish selectable text
Date/Time	Real Time Clock (RTC), To print date and time information (Dates in year/month/day, day/month/year or month/day/year formats- Battery backed)

3.0 INSTALLATION

3.1 LOCATING THE SCALE

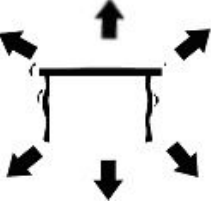
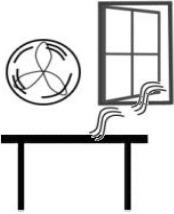
	<ul style="list-style-type: none">• The scales should not be placed in a location that will reduce the accuracy.• Avoid extremes of temperature. Do not place in direct sunlight or near air conditioning vents.
	<ul style="list-style-type: none">• Avoid unsuitable tables. The table or floor must be rigid and not vibrate.
	<ul style="list-style-type: none">• Avoid unstable power sources. Do not use near large users of electricity such as welding equipment or large motors.• Do not place near vibrating machinery.
	<ul style="list-style-type: none">• Avoid high humidity that might cause condensation. Avoid direct contact with water. Do not spray or immerse the scales in water.• Avoid air movement such as from fans or opening doors. Do not place near open windows or air-conditioning vents.• Keep the scales clean. Do not stack material on the scales when they are not in use.

3.2 INSTALLATION OF CBC-M SERIES

- The CBC-M Scales comes with a stainless steel platform packed separately.
- Place the platform in the locating holes on the top cover.
- **Do not** press with excessive force as this could damage the load cell inside.
- Level the scale by adjusting the four feet. The scale should be adjusted such that the bubble in the spirit level is in the centre of the level and the scale is supported by all four feet.
- Turn the power ON using the switch located on the right side of the base.
- The scale will show the current software revision number in the “Weight” display window (**V3.06A** where **3.06** indicates the current software revision number and **A** indicates that it is the approved model).
- Next a self-test is performed. At the end of the self-test, it will display “0” in all three displays, if the zero condition has been achieved.

4.0 KEY DESCRIPTIONS

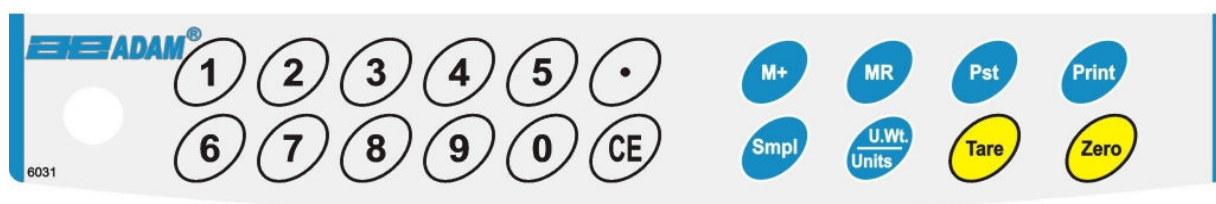

Keys	Functions
[0-9, .]	Numeric entry keys, used to manually enter a value for tare weights, unit weight, and sample size.
[CE]	Used to clear the unit weight or an erroneous entry.
[M+]	Add the current count to the accumulator. Up to 99 values or full capacity of the weight display can be added. Also prints the displayed values when Auto print is switched off.
[MR]	To recall the accumulated memory.

[Pst]	To set the upper limit for the number of items counted. When this upper limit is exceeded the scale will sound the beeper.
[Print]	To print the accumulated totals to a PC or printer using the RS-232 interface.
[Smpl]	Used to input the number of items in a sample.
[U.Wt./Units]	Used to enter the weight of a sample manually.
[Tare]	Tares the scale. Stores the current weight in memory as a tare value, subtracts the tare value from the weight and shows the results. This is the net weight. Entering a value using the keypad will store that as the tare value.
[Zero]	Sets the zero point for all subsequent weighing. It shows zero.

5.0 DISPLAYS

The scales have three digital display windows. These are “**Weight**”, “**Unit Weight**” and “**Count**”.

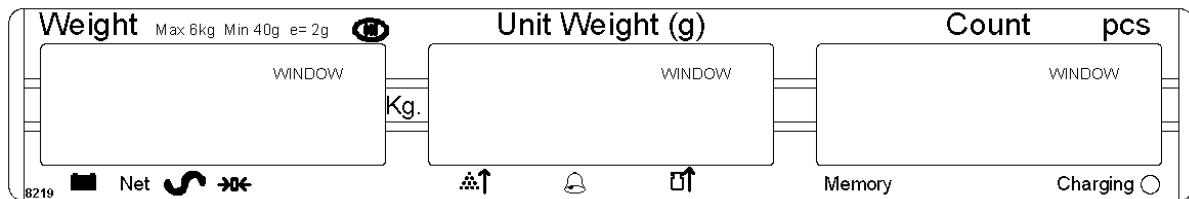

5.1 WEIGHT DISPLAY

It has 5-digit display to indicate the weight on the scale.

Arrows above symbols will indicate the following:



Low battery, 

Net Weight Display, "**Net**"

Stability indicator, "**Stable**" or symbol  as above.

Zero indicator, "**Zero**" or symbol  as above

5.2 UNIT WEIGHT DISPLAY

- This display will show the unit weight of a sample. This value is either input by the user or computed by the scale. The unit of measurement is kilograms on all **CBC-M** series.
- The arrow indicator will be seen above "**Sample**" or  symbol as above, when there is insufficient number of samples to accurately determine the count.
- When the unit weight is not large enough to determine an accurate count, the arrow indicator will be seen above "**U. Weight**" or  symbol as above.
- In both cases the scale continues to operate and the indications are to alert the user for a potential problem.
- If a preset count has been stored the "**Preset**" or  symbol as above, will have an arrow above.

5.3 COUNT DISPLAY

- This display will show the number of items on the scale or the value of the accumulated count. See the next section on OPERATION.
- The arrow indicator will be seen above "**Memory**" when a value has been entered into the memory.

6.0 OPERATION

6.1 ZEROING THE DISPLAY

- You can press the **[Zero]** key at any time to set the zero point from which all other weighing and counting is measured. This will usually be necessary only when the platform is empty. When the zero point is obtained the "**Weight**" display will show the indicator for zero.
- The scale has an automatic re-zeroing function to account for minor drifting or accumulation of material on the platform. However you may need to press **[Zero]** to re-zero the scale if small amounts of weight are still shown when the platform is empty.

6.2 TARING

- Zero the scale by pressing the **[Zero]** key if necessary. The indicator above “**Zero**” will be ON.
- Place a container on the platform, a value for its weight will be displayed.
- Press the **[Tare]** key to tare the scale. The weight that was displayed is stored as the tare value which is subtracted from the display, leaving zero on the display. The indicator above “**Net**” will be ON.
- As a product is added only the weight of the product will be shown. The scale could be tared a second time if another type of product was to be added to the first one. Again only the weight that is added after taring will be displayed.
- When the container is removed a negative value will be shown. If the scale was tared just before removing the container, this value is the gross weight of the container *plus* all products those were removed. The indicator above “**Zero**” will also be ON because the platform is back to the same condition as it was when the **[Zero]** key was pressed last.

6.3 PARTS COUNTING

6.3.1 Setting Unit Weight

In order to do parts counting it is necessary to know the average weight of the items to be counted. This can be done by weighing a known number of the items and letting the scale determine the average unit weight or by manually inputting a known unit weight using the keypad.

A. Weighing a sample to determine the Unit Weight

To determine the average weight of the items to be counted, you will need to place a known quantity of the items on the scale and then to key in the number of items being weighed. The scale will then divide the total weight by the number of items and display the average unit weight. Press **[CE]** anytime to clear the unit weight.

- Zero the scale by pressing the **[Zero]** key if necessary. If a container is to be used, place the container on the scale and tare by pressing **[Tare]** as discussed earlier.

- Place a known quantity of items on the scale. After the weight display is stable, enter the quantity of items using the numeric keys and then press the **[Smpl]** key.
- The number of units will be displayed on the "**Count**" display and the computed average weight will be shown on the "**Unit Weight**" display.
- As more items are added to the scale, the weight and the quantity will increase.
- If a quantity which is smaller than the sample is placed on the scale, then the scale will automatically enhance the Unit Weight by re-calculating it. To lock the Unit Weight and avoid re-sampling, press **[U. Wt./Units]**.
- If the scale is not stable, the calculation will not be completed. If the weight is below zero, the "**Count**" display will show negative count.

B. Entering a known Unit Weight

- If the unit weight is already known then it is possible to enter that value using the keypad.
- Enter the value of the unit weight in grams, using the numeric keys followed by pressing the **[U. Wt./Units]** key. The "**Unit Weight**" display will show the value as it was entered.
- The sample is then added to the scale and the weight will be displayed as well as the quantity, based on the unit weight.

6.3.2 Counting more parts

- After the unit weight has been determined or entered, it is possible to use the scale for parts counting. The scale can be tared to account for the container weight as discussed in the earlier section.
- After the scale is tared the items to be counted are added and the "**Count**" display will show the number of items, computed using the total weight and the unit weight.
- It is possible to increase the accuracy of the unit weight at

any time during the counting process by entering the count displayed and then pressing the **[Smpl]** key. You must be certain that the quantity displayed matches the quantity on the scale before pressing the key. The unit weight can be adjusted based upon a larger sample quantity. This will give greater accuracy when counting larger sample sizes.

6.3.3 Automatic part weight updates

- At the time of computing the unit weight (see section 6.3.1A), the scale will automatically update the unit weight when a sample less than the sample already on the platform is added. A beep will be heard when the value is updated. It is wise to check the quantity is correct when the unit weight has been updated automatically.
- This feature is turned off as soon as the number of items added exceeds the count used as a sample.

6.3.4 Check-counting

- Check-counting is a procedure to cause an alarm to sound when the number of items counted on the scale meets or exceeds a number stored in the memory by using the **[Pst]** key.
- The stored value is entered from the keyboard. Enter the numeric value to be stored using the numeric keys. Then press the **[Pst]** key to store the value.
- To clear the value from the memory and thereby turn off the check-counting feature, enter the value "0" and press **[Pst]**.

6.3.5 Manually Accumulated Totals

- The values (weight and count) shown on the display can be added to the values in the memory by pressing the **[M+]** key. The "**Weight**" display will show the total weight, the "**Count**" display will show the total accumulated count and the "**Unit Weight**" display shows the number of times, the items have been added to the memory for accumulation. The values will be displayed for 2 seconds before returning to normal.
- The scale must return to zero or a negative number, before another sample can be added to the memory.
- More products can then be added and the **[M+]** key to be

pressed again. This can continue for up to 99 entries or until the capacity of the “**Weight**” display is reached.

- To observe the total stored value, press the **[MR]** key. The total will be displayed for 2 seconds.
- To clear the memory- first press **[MR]** to recall the totals from memory and then press the **[CE]** key to clear all values from the memory.

6.3.6 Automatic Accumulated Totals

- The scale can be set to automatically accumulate totals when a weight is placed on the scale. This eliminates the need to press the **[M+]** key to store values into the memory. However the **[M+]** key is still active and can be pressed to store the values immediately. In this case the values will not be stored when the scale returns to zero.
- See the Section 8.0 on RS-232 Interface for details on how to enable Automatic Accumulation.

7.0 PARAMETERS

The parameters are set to customise the scale to suit the weighing applications. For CBC-M scales, it is necessary to enter a secure menu using a password to set some parameters. To proceed with the setting of these parameters, the security seal has to be broken.

Other parameters for the RS-232 interface, real time clock and the accumulation function can all be set by the user as described below.

8.0 RS-232 INTERFACE

The CBC-M scales include a bi-directional RS-232 interface. The scale when connected to a printer or computer outputs the weight, unit weight and count using the RS-232 interface.

Specifications:

RS-232 output of weighing data ASCII code Adjustable Baud rate, 600, 1200, 2400, 4800, 9600 and 19200 baud 8 data bits No Parity
--

Connector:

9 pin d-subminiature socket Pin 3 Output Pin 2 Input Pin 5 Signal Ground

The scale can be set to print text in English, French, German or Spanish. See the RS-232 parameters section for details.

Data Format-Normal Output:

Date	12/09/2006	
Time	14:56:27	
<lf><cr>		
Net Wt	1.234 Kg	
UnitWt.	123 g	
PCS	10 pcs	
<lf><cr>		
<lf><cr>		
		Includes 2 line feeds with carriage return

Data Format- Memory Recall Print:

Date	12/09/2006	
Time	14:56:27	
<lf><cr>		

<lf> <cr>		
		Includes 1 line feed
TOTAL		
No.	5	
Wt.	1.234 Kg	
PCS	10 pcs	
<lf><cr>		
		Includes 1 line feed

<lf><cr><lf><cr>		
		2 line feeds, carriage return

When printing continuously the format is:

Net	1.234 Kg	
U.W.	123 g	
PCS	10 pcs	
<lf>		
		Includes 2 line feeds
<lf>		

Pressing the **[MR]** key will not send the totals to the RS-232 when the continuous print is turned on.

The continuous print will only be for weight and display data that is current.

In other languages the format is the same but the text will be in the language selected.

DESCRIPTION	ENGLISH	FRENCH	GERMAN	SPANISH
Net weight	Net Wt.	Pds Net	Net-Gew	Pso Net
Weight per unit counted	Unit Wt.	Pds unit	Gew/Einh	Pso/Unid
Number of items counted	Pcs	Pcs	Stck.	Piezas
Number of weighing added to subtotals	No.	Nb.	Anzhl	Num.
Total weight and count printed	Total	Total	Gesamt	Total
Print date	Date	Date	Datum	Fecha
Print time	Time	Heure	Zeit	Hora

8.1 INPUT COMMANDS FORMAT

The scale can be controlled with the following commands. The commands must be sent in upper case letters, i.e. “T” not “t”. Press the Enter key of the PC after each command.

T<cr><lf>	Tares the scale to display the net weight. This is the same as pressing [Tare] key.
Z<cr><lf>	Sets the zero point for all subsequent weighing. The display shows zero.
P<cr><lf>	Prints the results to a PC or printer using the RS-232 interface. It also adds the value to the accumulation memory if the accumulation function is not set to automatic. In CBC-M, the [Print] key will either print the current items being counted or the results of the accumulation memory if [M+] is pressed first.
R<cr><lf>	Recall and Print- Same as if first the [MR] key and then the [Print] key is pressed. Will display the current accumulated memory and print the total results.
C<cr><lf>	Same as pressing [MR] first and then the [CE] key to erase the current memory.

8.2 RS-232 SETUP

The RS-232 interface uses parameters set by the user such as language, baud rate, printing mode, etc. Press and hold the **[Print]** key for 4 seconds to access the parameters. Use the **[U. Wt./Units]** key to change a parameter and the **[Tare]** key to confirm the change and then advance to the next parameter.

When a parameter is entered by pressing the **[Tare]** key, the displays will guide you through the parameter selected and the options available.

The parameters and their functions are:

Displays			Options	Functions
Weight	Unit Weight	Count		
Port	on		on or off	Enable or disable the RS-232 interface.
4800	bPS		600, 1200, 2400, 4800, 9600 or 19200	Set baud rate.
Print	mAn		Cont to PC, Print mAn, Print Auto	Select printing options for continuous out, print manually, or printing automatically
AC	mAn		AC mAn, AC Auto or AC off	Select the operation of the accumulation method manually, automatically or turned off.
CoUntr	Y E	nGLiSH	EnGLiSH, FrEnCH, GErMAN or SPAniSH	Select Language to be printed.

Scale will do the following depending on the Accumulation and Print settings:

PRINT FUNCTIONS	ACCUMULATION FUNCTIONS		
	AC Auto	AC mAn	AC off
Print Auto	Accumulate and print automatically	Print automatically Accumulate and print when [M+] is pressed	Print automatically, [M+] key has no function
Print mAn	Automatically Accumulate but not print, Print only when [Print] key pressed	Accumulate and print when [M+] or [Print] is pressed	Print when [Print] key is pressed, [M+] key has no function
Cont to PC	Print continuously and accumulate automatically when stable. [Print] key no function	Print continuously and accumulate when [M+] is pressed [Print] key no function	Print continuously [M+] and [Print] key have no function

8.3 REAL TIME CLOCK SETUP

The Real Time Clock (RTC) is used only for the RS-232 output. The Date and Time can be set as required. The scale will keep the clock running even when the power is off.

Setting up the clock

- Press and hold the **[CE]** key when power is first turned on, release the key when the revision is displayed. The initial displays show the current date and time set.

“ **rtC** “ **11,14,06**” **16,41,35**”

- Press the **[CE]** key to change the date and time. The display will show the current time format, “**H-m-S**”.
- Enter the time using the numeric keys using a 24 hour clock format, 3:41PM is “**154100**”.
- Press the **[Tare]** key to accept the time. The display will show the current date format.
- Press the **[Print]** key to change the date format. Available formats are:

“**Y-m-d**” year, month, day

“**m-d-Y**” month, day, year

“**d-m-Y**” day, month, year

- Press the **[Tare]** key to accept the chosen format and then enter the date in this format.
- Press the **[Tare]** key to accept the date.

An error code will be shown if the time (**Err 1**) or the date (**Err 2**) is not the permissible values. For example, 34th day of a month is an invalid entry.

8.4 AUTO SLEEP FUNCTION

This function may be enabled or disabled by the user. If enabled, when the scale is not used for some time (as pre-set by the user under this function) it automatically switches off. To set this parameter-

- During self-checking, press [**Zero**] and release at once. The display shows “**SLEEP mode**”.
- Press [**U. Wt./Units**] key to scroll through the auto sleep values.
 - “**0**” Auto sleep mode disabled
 - “**1**” Auto sleep after 1 minute
 - “**5**” Auto sleep after 5 minutes
 - “**10**” Auto sleep after 10 minutes
- Press [**Tare**] to set the value. The scale returns to zero.

9.0 BATTERY AND BACKLIGHT OPERATION

9.1 RECHARGEABLE BATTERY

- The scales can be operated from the battery, if desired. The battery life is approximately 90 hours.
- When the battery needs charging the arrow above the low battery symbol under the “**Weight**” display will turn on. The battery should be charged as soon as the arrow is on. The scale will still operate for about 10 minutes after which it will automatically switch off to protect the battery.
- To charge the battery, simply plug the scale into the mains and switch the mains power ON. The scale does not need to be turned on.
- The battery should be charged for at least 12 hours for full capacity.
- Just under the “**Count**” display is an LED to indicate the status of battery charging. When the scale is plugged into the mains power, the internal battery will be charged. If the LED is green the battery is fully charged. If it is red, the battery is nearly discharged and yellow indicates the battery should be charged longer, preferably overnight.
- If the battery has not been used properly or it is used for a number of years it may eventually fail to hold a full charge. If the battery life becomes unacceptable then contact your distributor or Adam Equipment.

9.2 BACKLIGHT FOR LCD

- The backlight of the LCD can be set to:
 1. Be on all the time
 2. Be on only when a weight is placed on the scale
 3. Turned off
- To set the backlight press and hold **[Pst]** key for 4 seconds.
- The weight display will show “**EL xx**” where **xx** is the current setting for the backlight.
- Press **[U. Wt./Units]** to scroll through the options.

“ EL on ”	Sets the backlight to be on at all times.
“ EL Au ”	Sets the backlight to operate automatically when a weight is placed on the scale or a key is pressed.
“ EL OFF ”	Sets the backlight to be off.

- Press the **[Tare]** key to store the value or press the **[Zero]** key to escape from this setting and return to weighing.

10.0 ERROR CODES

During the initial power-on testing or during operation, the scale may show an error message. The meaning of the error messages is described below.

If an error message is shown, repeat the step that caused the message, turning the balance on, carry out the calibration or other functions. If the error message is still shown contact your dealer for further support.

ERROR CODE	DESCRIPTION	POSSIBLE CAUSES
Err 1	Time input error.	Tried to set an illegal time, i.e. 26hours
Err 2	Date input error	Tried to set an illegal date, i.e. 36 th day
Err 4	Initial Zero is greater than allowed (typically 4% of the maximum capacity) when power is turned on or when the [Zero] key is pressed,	Weight is on the pan when turning the scale on. Excessive weight on the pan when zeroing the scale. Improper calibration of the scale. Damaged load cell. Damaged Electronics.
Err 6	A/D count is not correct when turning the scale on.	Platform is not installed. Damaged load-cell. Damaged electronics.

11.0 CALIBRATION

The CBC-M approved scales are sealed to prevent unauthorised calibration. Contact Adam Equipment or your supplier for more details.

11.1 CALIBRATION PROCEDURE

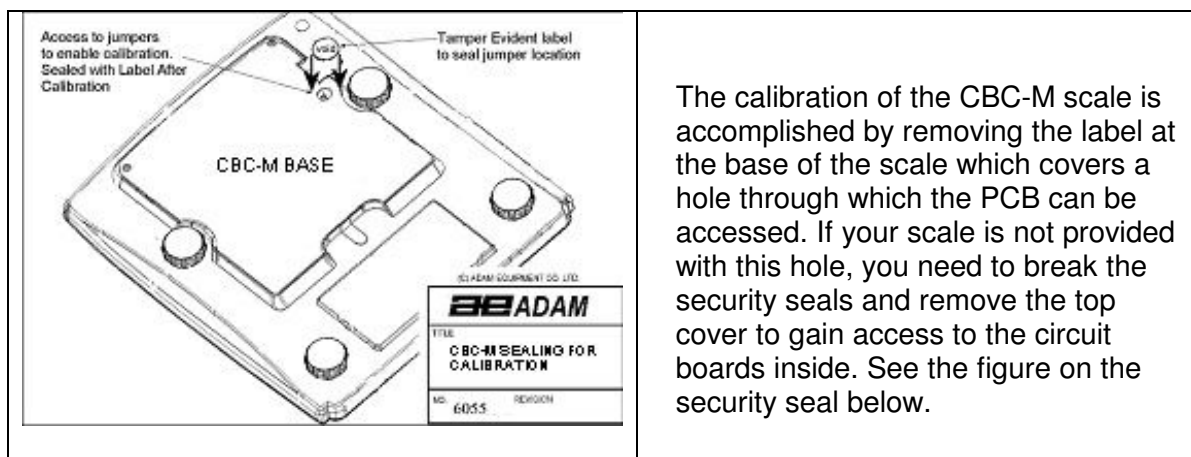

The calibration of the CBC-M scale is accomplished by removing the label at the base of the scale which covers a hole through which the PCB can be accessed. If your scale is not provided with this hole, you need to break the security seals and remove the top cover to gain access to the circuit boards inside. See the figure on the security seal below.

WARNING: CALIBRATION OF THE SCALES MAY MAKE IT ILLEGAL TO USE THE SCALES FOR SALES OF GOODS. CONTACT YOUR TRADING STANDARDS OFFICE FOR FURTHER ASSISTANCE.

11.2 SECURITY SEALS

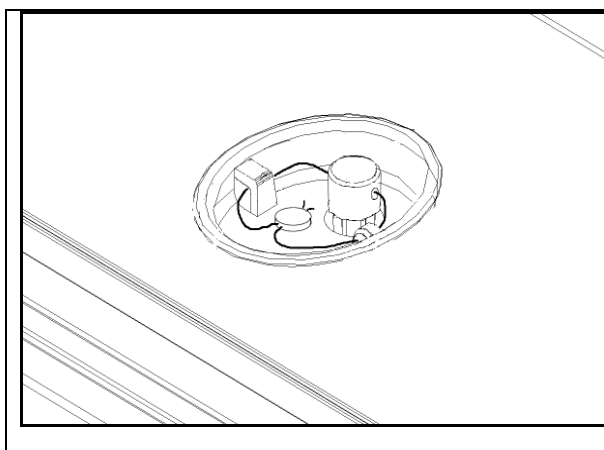

To seal the scale a lead-wire seal can be used as shown below. The base has a metal pin that protrudes through the cover. The security seal may be threaded through this metal pin, making it impossible to remove the cover without damaging either the security seal or the enclosure.

Metrology labels and additional security measures may be added to the scale as required by the national legislation.

An alternative method of sealing the scales is to have a seal covering the joint between the base and cover. If this seal is broken the scale must be sealed by the relevant authorities, using either the lead wire seal or an acceptable seal between the cover and base.

12.0 REPLACEMENT PARTS AND ACCESSORIES

If you need to order any spare parts and accessories, contact your supplier or Adam Equipment. A partial list of such items is as follows-

- Mains Power cord
- Replacement Battery
- Stainless Steel Pan
- In use cover
- Printer, etc.

13.0 SERVICE INFORMATION

This manual covers the details of operation. If you have a problem with the scale that is not directly addressed by this manual then contact your supplier for assistance. In order to provide further assistance, the supplier will need the following information which should be kept ready:

A. Details of your company

- Name of your company:
- Contact person's name:
- Contact telephone, e-mail, fax or any other methods:

B. Details of the unit purchased

(This part of information should always be available for any future correspondence. We suggest you to fill in this form as soon as the unit is received and keep a print-out in your record for ready reference.)

Model name of the scale:	CBC-__M
Serial number of the unit:	
Software revision number (Displayed when power is first turned on):	
Date of Purchase:	
Name of the supplier and place:	

C. Brief description of the problem

Include any recent history of the unit. For example:

- Has it been working since it's delivered
- Has it been in contact with water
- Damaged from a fire
- Electrical Storms in the area
- Dropped on the floor, etc.

WARRANTY INFORMATION

Adam Equipment offers Limited Warranty (Parts and Labour) for the components failed due to defects in materials or workmanship. Warranty starts from the date of delivery.

During the warranty period, should any repairs be necessary, the purchaser must inform its supplier or Adam Equipment Company. The company or its authorised Technician reserves the right to repair or replace the components at any of its workshops depending on the severity of the problems. However, any freight involved in sending the faulty units or parts to the service centre should be borne by the purchaser.

The warranty will cease to operate if the equipment is not returned in the original packaging and with correct documentation for a claim to be processed. All claims are at the sole discretion of Adam Equipment.

This warranty does not cover equipment where defects or poor performance is due to misuse, accidental damage, exposure to radioactive or corrosive materials, negligence, faulty installation, unauthorised modifications or attempted repair or failure to observe the requirements and recommendations as given in this User Manual.

Repairs carried out under the warranty does not extend the warranty period. Components removed during the warranty repairs become the company property.

The statutory right of the purchaser is not affected by this warranty. The terms of this warranty is governed by the UK law. For complete details on Warranty Information, see the terms and conditions of sale available on our web-site.

WEEE COMPLIANCE



Sealed Lead Acid
Battery
Must be recycled
Properly

Any Electrical or Electronic Equipment (EEE) component or assembly of parts intended to be incorporated into EEE devices as defined by European Directive 2002/95/EEC must be recycled or disposed using techniques that do not introduce hazardous substances harmful to our health or the environment as listed in Directive 2002/95/EC or amending legislation. Battery disposal in Landfill Sites is more regulated since July 2002 by regulation 9 of the Landfill (England and Wales) Regulations 2002 and Hazardous Waste Regulations 2005. Battery recycling has become topical and the Waste Electrical and Electronic Equipment (WEEE) Regulations are set to impose targets for recycling.



Adam Equipment

ADAM EQUIPMENT, BOND AVENUE, DENBIGH EAST INDUSTRIAL ESTATE, MILTON KEYNES, MK1 1SW, U.K.

Tel: (01908) 274545 Fax: (01908) 641339
Intl Tel: -44 1908 -274545 Intl Fax: -44 1908 641339
E-Mail Address: info@Adamequipment.co.uk

Table with CE mark and multilingual test certificate titles: Test Certificata, Prüfzertifikat, Certificat de test, Test certificaat, Certificato di prova, Certificado de prueba

The non-automatic weighing instrument
Die nicht-automatischen Wäageapparate
L'instrument de pesage à fonctionnement non automatique

Het niet-automatische weegwerktoig
Strumento per pesatura non automatico
Instrumento para pesaje non automatico



Table 1: Manufacturer: Adam Equipment Co. Ltd., Type: CBC-M, No of the EC type-approval certificate: T7095 / TC7096, Corresponds to the production model described in the EC type-approval certificate...

Table 2: Hersteller: Adam Equipment Co. Ltd., Typ: CBC-M, Nr. der EG-Bauartzulassung: T7095 / TC7096, Entspricht dem in der Bescheinigung über die Bauartzulassung beschriebenen Baumuster...

Table 3: Fabricant: Adam Equipment Co. Ltd., Type: CBC-M, N° du certificate d'approbation CE de type: T7095 / TC7096, Correspond au modèle décrit dans le certificat d'approbation CE de type...

Table 4: Fabrikant: Adam Equipment Co. Ltd., Type: CBC-M, Nummer van de Verklarling van EG-typegoedkeuring: T7095 / TC7096, Conform met het model beschreven in de verklaring van EG-typegoedkeuring...

Table 5: Produttore: Adam Equipment Co. Ltd., Modello: CBC-M, N. di certificato di approvazione di tipo CE: T7095 / TC7096, Conforme al modello di produzione descritto nel certificato di approvazione di tipo CE...

Table 6: Fabricante: Adam Equipment Co. Ltd., Tipo: CBC-M, Numero del certificado de aprobacion de tipo CE: T7095 / TC7096, Conforme al modelo de produccion descrito nel certificado de aprobacion del tipo CE...

Signature
Unterschrift
Signature
Handtekening
Firma
Firma

[Handwritten signature]

J.S. Cumbach
Technical Manager

Date
Datum
Date
Datum
Date
Datum
Date
Date
Date
Date

1 October 2007

ADAM EQUIPMENT is an ISO 9001:2000 certified global company with more than 35 years experience in the production and sale of electronic weighing equipment.

Adam products are predominantly designed for the Laboratory, Educational, Medical, retail and Industrial Segments. The product range can be described as follows:

- Analytical and Precision Balances
- Compact and Portable Balances
- High Capacity Balances
- Moisture analysers / balances
- Mechanical Scales
- Counting Scales
- Digital Weighing/Check-weighing Scales
- High performance Platform Scales
- Crane scales
- Medical Scales
- Retail Scales for Price computing

For a complete listing of all Adam products visit our website at
www.adamequipment.com

© Copyright by Adam Equipment Co. Ltd. All rights reserved. No part of this publication may be reprinted or translated in any form or by any means without the prior permission of Adam Equipment.

Adam Equipment reserves the right to make changes to the technology, features, specifications and design of the equipment without notice.

All information contained within this publication is to the best of our knowledge timely, complete and accurate when issued. However, we are not responsible for misinterpretations which may result from the reading of this material.

The latest version of this publication can be found on our Website.

www.adamequipment.com